



Convention Date (Germany) : Feb. 11, 1931.

372,099

Application Date (in United Kingdom) : May 11, 1931. No. 13,933 / 31.

Complete Accepted : May 5, 1932.

COMPLETE SPECIFICATION.

Improvements in or relating to Pocket Lighters.

We, MARTIN GRÜNSTEIN and LOUIS MÜLLER, trading as MÜLLER & GRÜNSTEIN, ELGERSBURGER FEUERZEUGFABRIK, of Elgersburg (Thuringia), Germany, both
 5 Citizens of the German State, do hereby declare the nature of this invention and in what manner the same is to be performed, to be particularly described and ascertained in and by the following
 10 statement:—

This invention relates to that class of pyrophoric friction wheel lighters in which a pivoted carrier for the wick cap is provided on the spindle of the friction wheel
 15 and is coupled to a ratchet wheel engaging in ratchet teeth provided on the edge of the friction wheel in such manner that the friction wheel is rotated on the opening of the wick cap carrier, but on the other hand
 20 does not move while the lighter is being closed.

The object of the invention is to enable the lighter to be easily worked with one hand by the particular construction of the various parts, their assembly and disposition with respect to the body of the lighter, to produce a jerky movement of the extinguishing-cap carrier and hence of the friction wheel so that a shower of
 25 sparks is produced and reliable action ensured.

According to the invention the extinguishing-cap carrier, which is in the form of a two-armed lever is subjected to the
 35 action of a spring through a rod which is pivoted at the end of the extinguishing-cap carrier opposite to that upon which is disposed the wick cap and is guided in a sleeve provided in the lighter casing, the extinguishing-cap carrier
 40 being maintained in the normal position by a two-armed manually operated lever mounted under spring pressure.

Furthermore, the upper end of the rod, which is pivoted to the extinguishing-cap carrier, is, according to the invention, bent in the direction of the cap, so that a large rocking angle and a sudden movement of the extinguishing-cap carrier are obtained.
 45

A further feature of the invention is that the extinguishing-cap carrier and the finger pressure lever are mounted one behind the other on parallel spindles
 50

carried by two parallel bearing plates integral with the cover plate of the lighter casing. 55

The invention is diagrammatically illustrated by way of example in the accompanying drawings.

Figure 1 is a sectional elevation on a centre line through the lighter. 60

Figure 2 is a corresponding front elevation.

Figure 3 is a side elevation of the upper part of the lighter with the extinguishing cap open. 65

The fuel container 2 is inserted in the casing 1 of the lighter and can be removed from below, the opening through which it is filled being closed by a screw plug 3 through which the wick 4 passes. The middle of the container 2 is provided
 70 hollow to afford room for the internally disposed flint-holding sleeve 5 and the spring-containing sleeve 6. The cover plate 7 is secured to the casing 1 and carries two parallel bearing plates 8 integral with the cover plate 7. In the cover plate 7 are fixed the wick tube 9, the flint-holding sleeve 5, and the spring-containing sleeve 6. 75

The bearing plates 8 carry two parallel spindles 10 and 11 one behind the other. The spindle 10 has mounted upon it the friction wheel 12, the ratchet wheel 13 and the extinguishing-cap carrier 14 with the extinguishing-cap 15. Through the opposite end of the arm of the extinguishing-cap carrier 14, which is in the form of a two-armed lever, passes a bearing pin 16 to which is attached the ratchet wheel 13 and a rod 17 the upper end 18 of which is bent in the direction of the extinguishing-cap. As the point of connection of the rod to the carrier 14 is displaced from
 85 the line of movement of the rod the angle through which the lever is turned for a determined movement of the rod is increased and at the same time a quicker movement of the carrier 14 is secured. 90

The free end of the rod 17 is guided in the sleeve 6 by means of a loosely mounted head 19. A helical compression spring 20 lying between the head 19 and the upper end of the spring sleeve 6 which is reduced
 95 to a slot for the passage of the connecting 105

[Price 1/-]

rod 17 keeps the rod under tension. The lower end of the spring sleeve 6 is sealed by a screw 21.

5 The two-armed lever 22 is mounted in line with the extinguishing-cap carrier 14 on the spindle 11 carried by the bearing plates 8. The lever 22 is controlled by a spring 23. The front arm of the lever 22 co-operates with the rear end of the extinguishing-cap carrier 14 so that 10 when pressure is applied upon the rear end of the finger lever 22 the rear end of the extinguishing-cap carrier 14 is released, and thus the latter is spun round by the 15 force exerted of the spring 20 and the friction wheel 13 simultaneously set in motion, sparks being thrown by the flint on the wick.

20 When the extinguishing-cap carrier 14 is closed its rear end slightly raises the finger lever 22 until the latter snaps back into the normal position under the pressure of the spring 23 and thus locks the extinguishing-cap carrier.

25 Having now particularly described and ascertained the nature of our said invention and in what manner the same is to be performed, we declare that what we claim is:—

30 1. A pyrophoric friction wheel lighter

of the class described provided with an extinguishing-cap carrier, which is in the form of a two-armed lever and is subjected to the action of a spring through a rod 35 which is pivoted at the end of the extinguishing-cap carrier opposite to that upon which is disposed the wick cap and is guided in a sleeve provided in the lighter casing, the extinguishing-cap carrier being maintained in the normal 40 position by a two-armed manually operated lever mounted under spring pressure.

2. A lighter according to claim 1, characterised in that the upper end of the rod 45 pivoted to the extinguishing-cap carrier is bent in the direction of the extinguishing-cap so as to obtain a large rocking angle of and a sudden movement of the extinguishing-cap carrier.

3. A lighter according to claim 1, 50 characterised in that the extinguishing-cap carrier and the finger pressure lever are mounted one behind the other on parallel spindles carried by two parallel bearing plates integral with the cover 55 plate of the lighter casing.

Dated this 11th day of May, 1931.

EDWARD EVANS & Co.,
27, Chancery Lane, London, W.C.2,
Agents for the Applicants.

[This Drawing is a reproduction of the Original on a reduced scale.]

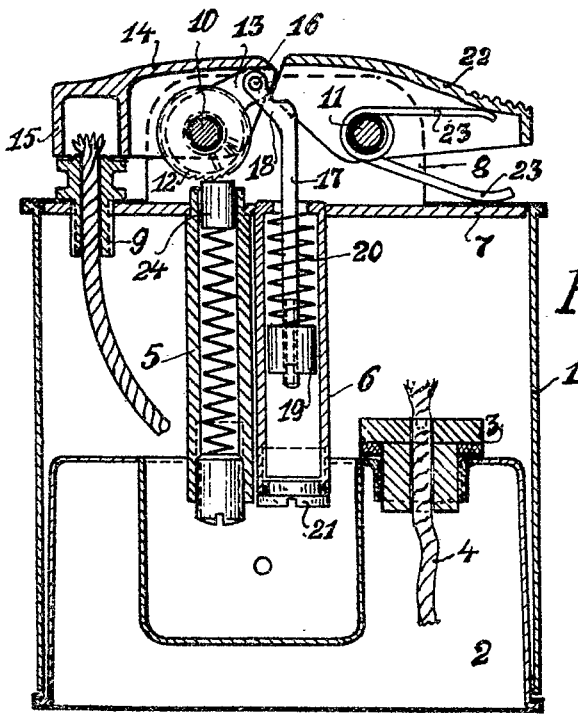

Fig. 1.

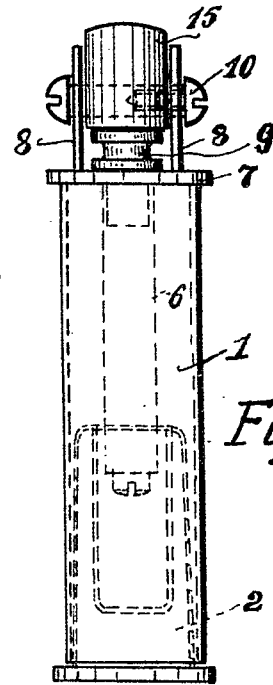

Fig. 2.

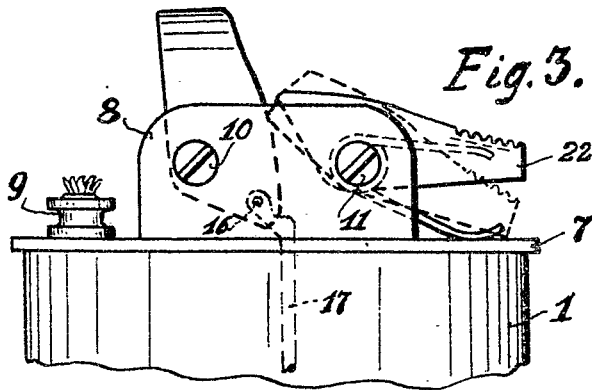

Fig. 3.