

PATENT SPECIFICATION



Convention Date (Austria): Feb. 22, 1934.

424,613

Application Date (in United Kingdom): Sept. 3, 1934. No. 25319/34.

Complete Specification Accepted: Feb. 25, 1935.

COMPLETE SPECIFICATION

Improvements relating to Pyrophoric Lighters

ERRATUM

SPECIFICATION No. 424,613.

Page 1, line 39, for "closer" read
"closed"

THE PATENT OFFICE,
May 28th, 1935.

turning of the cap to open the lighter rotates the friction wheel. By this arrangement force is applied to both walls of the cap on the two sides of the friction wheel in an absolutely accurate and symmetrical manner for the purpose of opening the cap, and the construction is simplified.

By way of example, a constructional form of lighter embodying the foregoing and other features of the invention is illustrated on the accompanying drawing.

Fig. 1 is a sectional view of the lighter in a plane parallel to one broad side thereof, and

Fig. 2 represents a section in a plane at right angles to that of Fig. 1. in both cases in the closer position of the lighter.

Fig. 3 is a side elevation of the lighter in open position.

Fig. 4 shows a side elevation and a plan of the casing with a bent-up bearing reinforcement.

Fig. 5 illustrates the bearing reinforcement alone in side elevation and plan.

Pivoted to the casing 1 with the aid of a pin 3 there is a pressure-operable lever 2 which has teeth 4 formed at its upper end, these teeth being adapted to mesh with projections 7 pressed out of the side walls 6 of the closing cap 5 on both sides

[Price 1/-]

by louvers 15. It has been found that with the provision of such shielded slots the flame burns higher in strong wind and is not extinguished as usual with other arrangements.

Having now particularly described and ascertained the nature of my said invention and in what manner the same is to be performed, I declare that what I claim is:—

1. A pressure operated pyrophoric lighter of the type wherein a pressure-operable lever pivoted to the casing actuates a turnable closing cap and spark-producing means, characterised in that in both side walls of the closing cap pins or teeth or the like are provided which mesh with teeth on the pressure-operable lever, so that the latter directly actuates the closing cap.

2. A lighter according to claim 1, wherein the said projections are pressed up from the walls of the closing cap.

3. A lighter according to claim 1 or 2. wherein the casing consists of sheet metal bent to U-form.

4. A lighter according to any of claims 1 to 3, wherein cheeks on the casing affording bearings for the closing cap are held together by a U-shaped clamping member.

5. A pressure - operated pyrophoric

Price 4s 6d

RESERVE COPY

PATENT SPECIFICATION



Convention Date (Austria): Feb. 22, 1934.

424,613

Application Date (in United Kingdom): Sept. 3, 1934. No. 25319/34.

Complete Specification Accepted: Feb. 25, 1935.

COMPLETE SPECIFICATION

Improvements relating to Pyrophoric Lighters

I, ALOIS KAUFMANN, an Austrian citizen, of 57, Pernerstorfergasse, Vienna X, Austria, do hereby declare the nature of this invention and in what manner the same is to be performed, to be particularly described and ascertained in and by the following statement:—

This invention relates to pyrophoric lighters of the type wherein a pressure-operable lever pivoted to the casing actuates a turnable closing cap and spark-producing means.

According to the invention pins or teeth or the like are provided in both side walls of the closing cap and mesh with teeth, on the pressure-operable lever, so that the latter directly actuates the closing cap. The spark-producing means, which may be a friction wheel, is actuated in a known manner by the closing cap, to which it is operatively connected so that, at least, turning of the cap to open the lighter rotates the friction wheel. By this arrangement force is applied to both walls of the cap on the two sides of the friction wheel in an absolutely accurate and symmetrical manner for the purpose of opening the cap, and the construction is simplified.

By way of example, a constructional form of lighter embodying the foregoing and other features of the invention is illustrated on the accompanying drawing.

Fig. 1 is a sectional view of the lighter in a plane parallel to one broad side thereof, and

Fig. 2 represents a section in a plane at right angles to that of Fig. 1, in both cases in the closer position of the lighter.

Fig. 3 is a side elevation of the lighter in open position.

Fig. 4 shows a side elevation and a plan of the casing with a bent-up bearing reinforcement.

Fig. 5 illustrates the bearing reinforcement alone in side elevation and plan.

Pivoted to the casing 1 with the aid of a pin 3 there is a pressure-operable lever 2 which has teeth 4 formed at its upper end, these teeth being adapted to mesh with projections 7 pressed out of the side walls 6 of the closing cap 5 on both sides

[Price 1/-]

Price 4s 6d

so as to extend inwardly. The inter-engagement of the teeth 4 and the projections 7 causes the closing cap to be positively turned when the lever 2 is rocked. Connected to the closing cap 5 there is an actuating member 8 which turns the friction wheel 9 when the closing cap is turned to open the lighter, and thereby causes the flint 10 to emit sparks which ignite the wick.

For the reinforcement of the bearing for the friction wheel spindle 11, as well as for closing up the rear side of the lighter, i.e., for holding together the bearing discs 12, a clamping member 13 bent to U-shape, as shown in Fig. 5, is pushed over the discs 12. This member also acts as a stop for the lever 2, so that it always returns to the same inoperative position.

Air inlet slots 14 are disposed in the side walls of the casing 1 and are shielded by louvers 15. It has been found that with the provision of such shielded slots the flame burns higher in strong wind and is not extinguished as usual with other arrangements.

Having now particularly described and ascertained the nature of my said invention and in what manner the same is to be performed, I declare that what I claim is:—

1. A pressure operated pyrophoric lighter of the type wherein a pressure-operable lever pivoted to the casing actuates a turnable closing cap and spark-producing means, characterised in that in both side walls of the closing cap pins or teeth or the like are provided which mesh with teeth on the pressure-operable lever, so that the latter directly actuates the closing cap.

2. A lighter according to claim 1, wherein the said projections are pressed up from the walls of the closing cap.

3. A lighter according to claim 1 or 2, wherein the casing consists of sheet metal bent to U-form.

4. A lighter according to any of claims 1 to 3, wherein cheeks on the casing affording bearings for the closing cap are held together by a U-shaped clamping member.

5. A pressure - operated pyrophoric

424613

lighter substantially as herein described
and illustrated.

Dated this 3rd day of September, 1934.

H. D. FITZPATRICK & Co.,
Chartered Patent Agents,
49, Chancery Lane, London, W.C.2,
and
94, Hope Street, Glasgow.

Leamington Spa: Printed for His Majesty's Stationery Office, by the Courier Press.—1935.

Fig.1

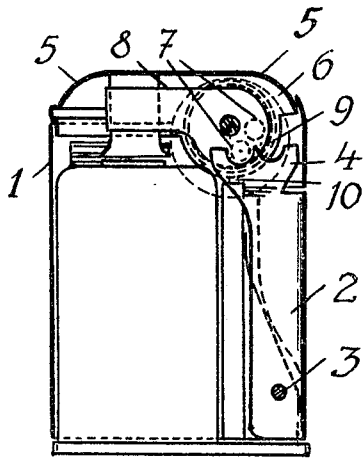

Fig.3

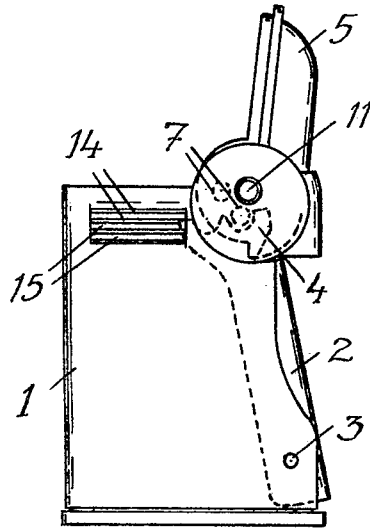

Fig.2

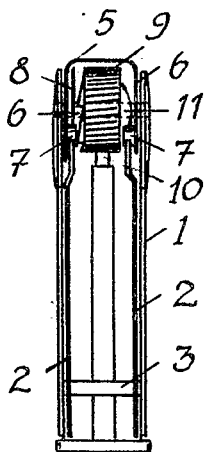
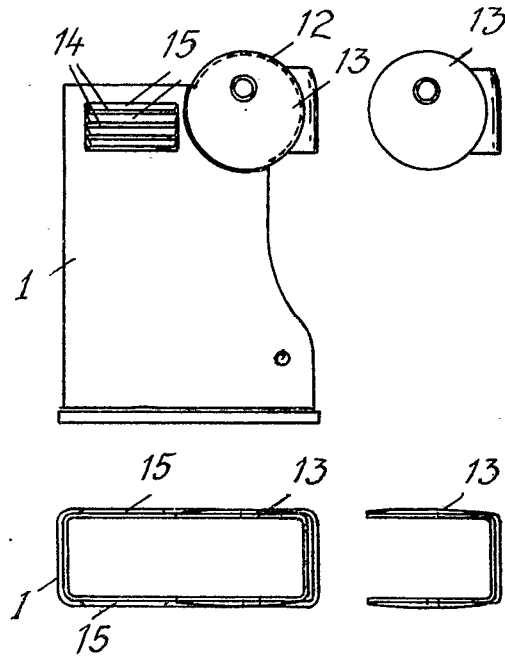

Fig.4

Fig.5



[This Drawing is a reproduction of the Original on a reduced scale.]