

RESERVE COPY.
PATENT SPECIFICATION

350,695

Convention Date (Germany): May 23, 1929.

Application Date (in United Kingdom): May 22, 1930. No. 15,753/30.

Complete Accepted: June 18, 1931

COMPLETE SPECIFICATION.

Benzine or like Lighters.



I, LUDWIG ZWILLING, a German citizen, trading as the firm ELEKTROTECHNISCHE FABRIK LUDWIG ZWILLING, of No. 14, Ludwigstrasse, Walldorf, Hessen, Germany, do hereby declare the nature of this invention and in what manner the same is to be performed, to be particularly described and ascertained in and by the following statement:—

10 In benzine or like lighters of the kind in which the wick is lighted by an electrically heated ignition spiral or by a spark produced by friction from a cerium iron alloy or the like, a difficulty lies in the production of an air-fuel mixture within the range of the ignition device effective at the instant of the spark production or of the attaining of the ignition temperature.

20 According to the invention the vessel containing the liquid fuel for the wick is provided with a device for the production of an overpressure therein simultaneously with the operation of the ignition means so as to force vaporous fuel from the fuel container into the ignition space.

30 The device for the production of an overpressure in the fuel container may consist of a pump, for example an air pump built on the container or of a displacer body, which reduces the volume of the fuel container.

35 An embodiment of the invention is illustrated in the accompanying drawing in which:—

40 Fig. 1 shows the lighter in longitudinal section and

Fig. 2 in top plan view with the lid removed.

In the illustrations 1 is the casing of the benzine lighter, which is provided with a lid 20 hinged thereon by a hinge 2. In this lighter casing the dry battery 3 is inserted, which rests on an insulator 4 and supplies current through a contact spring 5 to a contact spring 6 insulated by an insulator 7. A contact spring 8 of the dry battery bears on a metal part 50 metallicly connected with the casing 1 this contact spring 8 forming the second pole. 9 is the ignition wire, which is consequently supplied with current as soon as

[Price 1/-]

the carrier 10 of the ignition wire 9 is moved downwards by means of the handle 19 so that the contact spring 6 comes into contact with the carrier 10. Current flows then from the dry battery 3 through spring 5, contact spring 6, carrier 10, ignition wire 9, casing 1 to the contact spring 8. The carrier 10 with the handle 19 of the ignition wire 9 is fastened to the casing part 11, which slides tightly in the casing part 12 against the action of a spring 13. In the space between the two casing parts 11 and 12 the benzine or like liquid fuel, as also the wick 14 are arranged, the free end of which wick extends to the outer side through the wick sleeve 15. The two casing parts can be pushed out of the casing 1 and opened by unscrewing the screw part 16 for filling in the fuel. A narrow channel opening 17 is provided in the sleeve 15.

The operation of the pocket lighter is as follows:

After the lid 20 has been opened by depressing the snap lock 18, the casing part 11 is pressed downwards by the handle 19 into the casing part 12 against the action of the spring 13. Consequently fuel vapour enclosed in the two part container is forced out through the narrow passage 17. At the same time by depressing the handle 19 the carrier 10 of the ignition wire 9 is brought into contact in the manner described, with the contact spring 6, so that the glowing ignition wire is situated in the path of the vapour current, forced out through the channel 17 and ignites this vapour. By this ignition flame the wick, which projects from the sleeve 15 is ignited. As soon as the lid 20 is again engaged in the snap lock 18, the flame of the lighter is extinguished.

Lighters for lamps and other purposes, for example gas lighters can be made in a similar manner.

Having now particularly described and ascertained the nature of my said invention and in what manner the same is to be performed, I declare that what I claim is:—

1.—Benzine or like lighter of the kind described characterized in that the con-

55

60

65

70

75

80

85

90

95

- tainer containing the liquid fuel for the wick is fitted with a device for the production of an overpressure in the same simultaneously with the operation of the ignition means so as to force vaporous fuel from the container into the ignition space. 20
- 2.—Benzine or like lighter as claimed in claim 1, characterized in that the container containing the liquid fuel with the projecting wick comprises a displacer shiftable against the action of a spring and a narrow vapour channel ending in proximity to the electric incandescent wire. 25
- 3.—Benzine or like lighter as claimed in claims 1 and 2, characterized in that the container containing the liquid fuel is made of two parts, of which the one part is stationarily fixed in the casing of the apparatus, whereas the other part is pushed into or over the first mentioned part. 30
- 4.—Benzine or like lighter as claimed in claims 1, 2 and 3, characterized in that the movable part of the fuel container is movable with the ignition device, so that at the same time as the vapour current issues from the fuel container the ignition device is actuated. 30

Dated this 22nd day of May, 1930.

CHATWIN & COMPANY,

Patent Agents for the Applicant,

Orion House,

253, Gray's Inn Road, London, W.C. 1.

[This Drawing is a reproduction of the Original on a reduced scale.]

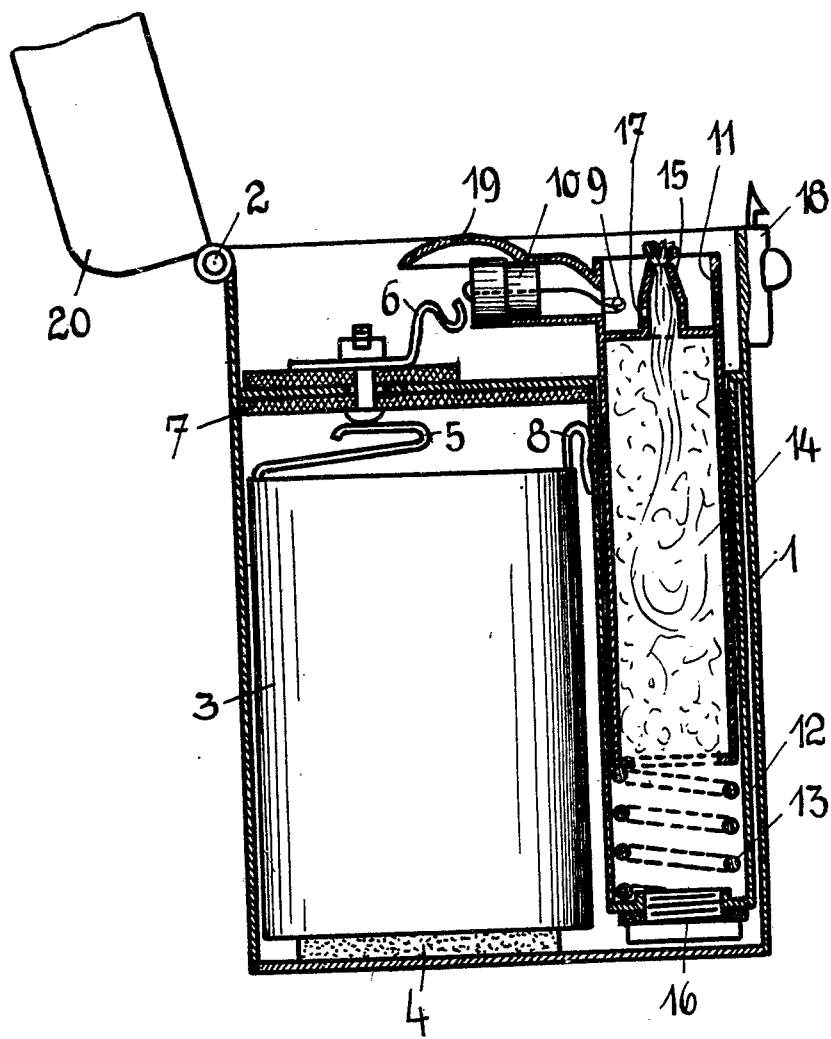

Fig. 1.

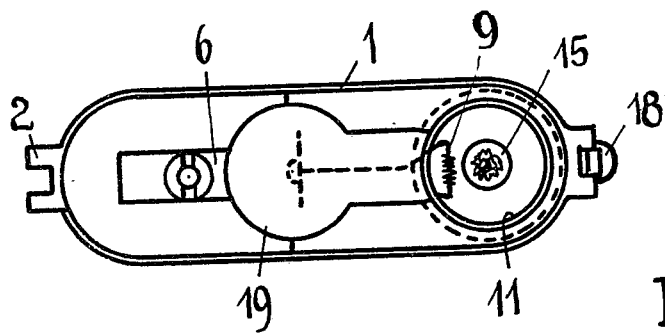

Fig. 2.